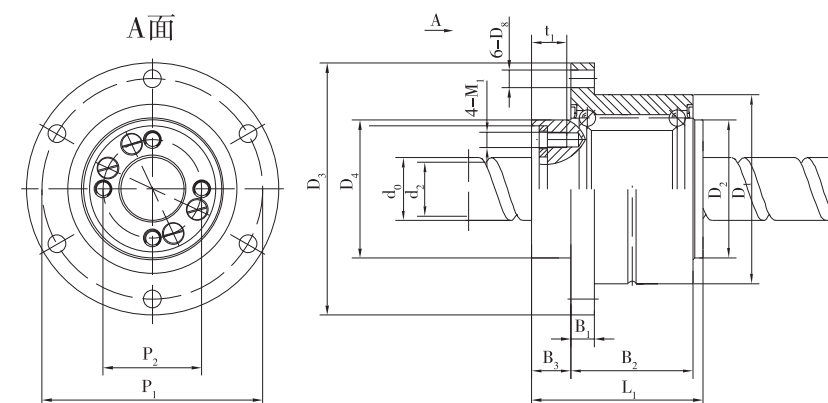
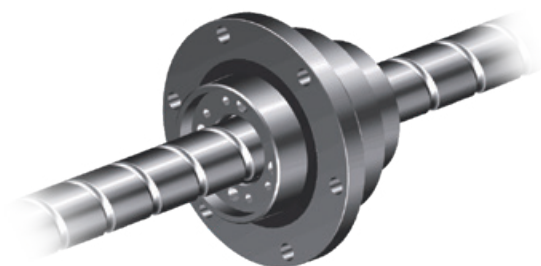
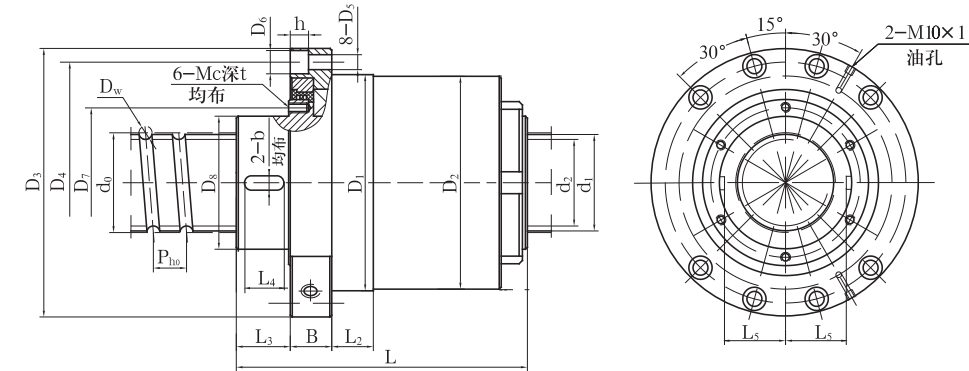

XDK轻载型旋转螺母组合单元

规格代号	公称直径	公称导程	丝杠外径 d_1	负荷滚珠圈数	滚珠直径 D_w	丝杠底径 d_2	螺母安装尺寸											丝杠基本额定载荷		支撑轴承基本额定载荷		规格代号		
							D_1 (g6)	L_1	D_2	D_3	D_4 (h7)	P_1	P_2	B_1	B_2	B_3	M_1	D_8	t_1	动载荷 C_a (kN)	静载荷 C_{0a} (kN)		动载荷 C_a (kN)	静载荷 C_{0a} (kN)
XDK1616R-S3-2	16	16	16	2	2.778	8.8	48	45	35	64	36	56	25	6	21	10	4	4.5	14	4.3	6.5	6.5	9.3	XDK1616R-S3-2
XDK2020R-S3-2	20	20	20	2	3.175	17.7	56	52	39	72	43.5	64	31	6	21	11	5	4.5	18	5.8	9.5	7.1	12	XDK2020R-S3-2
XDK2525R-S4-2	25	25	25	2	3.969	22.1	66	66	50	86	52	75	38	7	25	13	6	5.5	18	10.1	17.9	10.3	18.5	XDK2525R-S4-2
XDK3232R-S5-2	32	32	32	2	4.763	28.1	78	78	58	103	63	89	48	8	25	14	6	6.6	17	14.3	27.2	11.3	22.9	XDK3232R-S5-2

XJD重载型旋转螺母组合单元

规格代号	公称直径 d_0	公称导程 P_{h0}	丝杠外径 d_1	滚珠直径 D_w	丝杠底径 d_2	负荷滚珠圈数 n	额定动载荷 C_a kN	极限轴向载荷① C_{0a} MAXkN	L	螺母座安装尺寸									同步带轮(齿轮)安装尺寸						规格代号		
										D_1 (g6)	D_2 ($^{0.1}_{-0.2}$)	L_2	D_3	B	D_4	D_5	D_6	h	D_7	D_8 (g6)	L_3	b(N9)	L_4	L_5 ($^{0}_{-0.2}$)		Mc	t
XJD6316R-S10-7	63	16	61	10	53.8	7	175	570	360	195	195	40	243	40	219	13.5	20	13	118	100	50	12	40	45.5	8	15	XJD6316R-S10-7
XJD6320R-S10-6	63	20	61	10	53.8	6	153	488	360	195	195	40	243	40	219	13.5	20	13	118	100	50	12	40	45.5	8	15	XJD6320R-S10-6
XJD8016R-S10-8	80	16	78	10	70.7	8	223	850	360	220	220	50	280	50	250	17.5	26	17.5	138	120	50	12	40	55.5	10	20	XJD8016R-S10-8
XJD8020R-S13-6	80	20	78	12.7	68.8	6	235	789	360	220	220	50	280	50	250	17.5	26	17.5	138	120	50	12	40	55.5	10	20	XJD8020R-S13-6
XJD8025R-S13-5	80	25	78	12.7	68.8	5	201	656	360	220	220	50	280	50	250	17.5	26	17.5	138	120	50	12	40	55.5	10	20	XJD8025R-S13-5
XJD8032R-S13-4	80	32	78	12.7	68.8	4	165	523	360	220	220	50	280	50	250	17.5	26	17.5	138	120	50	12	40	55.5	10	20	XJD8032R-S13-4
XJD8040R-S13-3	80	40	78	12.7	68.8	3	128	391	360	220	220	50	280	50	250	17.5	26	17.5	138	120	50	12	40	55.5	10	20	XJD8040R-S13-3
XJD10016R-S10-8	100	16	97	10	89.7	8	249	1087	375	245	245	50	319	50	282	22	33	21.5	165	145	50	12	40	68	12	25	XJD10016R-S10-8
XJD10020R-S13-7	100	20	97	12.7	87.8	7	298	1144	375	245	245	50	319	50	282	22	33	21.5	165	145	50	12	40	68	12	25	XJD10020R-S13-7
XJD10025R-S16-5	100	25	97	15.875	85.5	5	290	966	375	245	245	50	319	50	282	22	33	21.5	165	145	50	12	40	68	12	25	XJD10025R-S16-5
XJD10032R-S16-4	100	32	97	15.875	85.5	4	239	771	375	245	245	50	319	50	282	22	33	21.5	165	145	50	12	40	68	12	25	XJD10032R-S16-4
XJD10040R-S16-3	100	40	97	15.875	85.5	3	185	577	375	245	245	50	319	50	282	22	33	21.5	165	145	50	12	40	68	12	25	XJD10040R-S16-3

注1: 如标准尺寸不能满足需方设计需求, 请联系我公司特殊订货。

注2: 当轴向力超过额定动载荷时请与我司联系。