

DKF型高速精密滚珠丝杠副

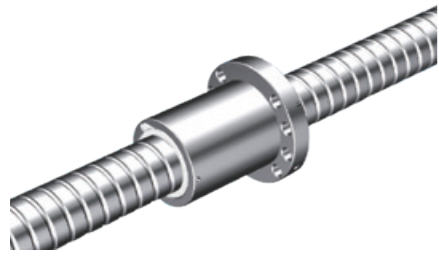

注:

- 1) K_c 是在预紧力 F_p 为 $0.1C_a$, 轴向载荷 F 为 $0.3C_a$ 时的理论计算值;
- 2) 当轴向载荷 F 不等于 $0.3C_a$ 时,

$$K'_c = K_c \left(\frac{F}{0.3C_a} \right)^{\frac{1}{3}}$$

式中

K_c 是表中的刚度值;

- 3) 该类型的滚珠丝杠副适用于高速应用场合;
- 4) 正常工作环境温度范围 $\pm 80^\circ\text{C}$;
- 5) 有特殊要求应在订货时提出。

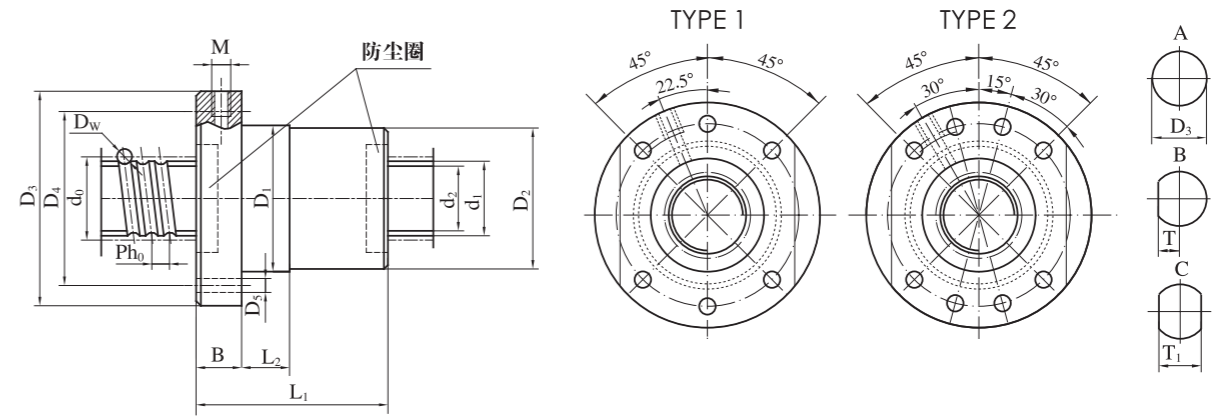

规格代号	公称直径 d_0	公称导程 P_{h0}	丝杠外径 d_1	钢球直径 D_w	丝杠底径 d_2	循环圈数 n	基本额定负荷		刚度 K_c N/ μm	螺母安装连接尺寸							规格代号					
							动载荷 C_a kN	静载荷 C_{0a} kN		$D_1(g6)$	$D_2(^{+0.1}_{-0.3})$	L_2	D_3	B	D_4	D_5		TYPE	T	T_1	M	L_1
DKF2010-3	20	10	20	3.175	17.8	3	10.8	19.6	269	36	36	15	58	11	47	6.6	1	22	44	M6	54	DKF2010-3
DKF2510-3	25	10	25	3.969	21.7	3	15.7	29.3	318	45	45	20	65	11	54	6.6	1	25.5	51	M6	50	DKF2510-3
DKF2510-4	25	10	25	3.969	21.7	4	20.5	39.9	428	45	45	20	65	11	54	6.6	1	25.5	51	M6	60	DKF2510-4
DKF2516-3	25	16	25	3.969	21.7	3	15.5	28.9	317	45	45	20	65	11	54	6.6	1	25.5	51	M6	71	DKF2516-3
DKF2516-4	25	16	25	3.969	21.7	4	20.2	39.4	427	45	45	20	65	11	54	6.6	1	25.5	51	M6	87	DKF2516-4
DKF2520-3	25	20	25	3.969	21.7	3	15.7	30.0	326	45	45	20	65	11	54	6.6	1	25.5	51	M6	80	DKF2520-3
DKF2816-4	28	16	28	3.969	24.7	4	21.8	45.8	481	50	50	20	80	11	65	6.6	1	31	62	M6	86	DKF2816-4
DKF3206-4	32	6	32	3.969	28.7	4	23.4	52.8	504	53	53	20	87	12	72	9	1	31	62	M6	46	DKF3206-4
DKF3206-5	32	6	32	3.969	28.7	5	28.7	66.9	633	53	53	20	87	12	72	9	1	31	62	M6	52	DKF3206-5
DKF3210-4	32	10	32	3.969	28.7	4	23.3	52.7	525	53	53	20	87	12	72	9	1	31	62	M6	63	DKF3210-4
DKF3210-5	32	10	32	3.969	28.7	5	28.6	66.7	658	53	53	20	87	12	72	9	1	31	62	M6	73	DKF3210-5
DKF3210-4	32	10	32	6.35	26.9	4	42.7	80.7	547	62	62	20	92	14	77	9	1	37	74	M6	67	DKF3210-4
DKF3210-5	32	10	32	6.35	26.9	5	52.3	102.3	686	62	62	20	92	14	77	9	1	37	74	M6	77	DKF3210-5
DKF3212-4	32	12	32	3.969	28.7	4	23.3	52.6	529	53	53	20	87	12	72	9	1	31	62	M6	68	DKF3212-4
DKF3212-5	32	12	32	3.969	28.7	5	28.5	66.6	663	53	53	20	87	12	72	9	1	31	62	M6	80	DKF3212-5
DKF3212-4	32	12	32	6.35	26.9	4	42.6	80.6	551	62	62	20	92	14	77	9	1	37	74	M6	75	DKF3212-4
DKF3212-5	32	12	32	6.35	26.9	5	52.2	102.1	690	62	62	20	92	14	77	9	1	37	74	M6	87	DKF3212-5
DKF3216-4	32	16	32	6.35	26.9	4	42.3	80.2	553	62	62	20	92	14	77	9	1	37	74	M6	92	DKF3216-4
DKF3220-3	32	20	32	3.969	28.7	3	17.5	38.1	394	53	53	20	87	12	72	9	1	31	62	M6	81	DKF3220-3
DKF3616-5	36	16	36	6.35	30.9	5	55.4	115.4	764	66	66	20	96	14	81	9	2	36.5	73	M8x1	106	DKF3616-5
DKF4010-4	40	10	40	6.35	34.9	4	48.0	102.6	648	70	70	20	100	14	85	9	2	37.5	75	M8x1	72	DKF4010-4
DKF4010-5	40	10	40	6.35	34.9	5	58.9	130.0	813	70	70	20	100	14	85	9	2	37.5	75	M8x1	82	DKF4010-5
DKF4012-4	40	12	40	6.35	34.9	4	47.9	102.5	656	70	70	20	100	14	85	9	2	37.5	75	M8x1	76	DKF4012-4
DKF4012-5	40	12	40	6.35	34.9	5	58.8	129.8	822	70	70	20	100	14	85	9	2	37.5	75	M8x1	88	DKF4012-5
DKF4015-5	40	15	40	6.35	34.9	5	58.6	129.5	830	70	70	20	100	14	85	9	2	37.5	75	M8x1	108	DKF4015-5
DKF4016-4	40	16	40	6.35	34.9	4	47.7	102.1	663	70	70	20	100	14	85	9	2	37.5	75	M8x1	91	DKF4016-4
DKF4016-5	40	16	40	6.35	34.9	5	58.5	129.4	831	70	70	20	100	14	85	9	2	37.5	75	M8x1	107	DKF4016-5
DKF4020-4	40	20	40	6.35	34.9	4	47.5	101.7	665	70	70	20	100	14	85	9	2	37.5	75	M8x1	110	DKF4020-4
DKF4020-5	40	20	40	6.35	34.9	5	58.2	128.8	833	70	70	20	100	14	85	9	2	37.5	75	M8x1	130	DKF4020-5
DKF4025-4	40	25	40	6.35	34.9	4	47.1	101.0	662	70	70	20	100	14	85	9	2	37.5	75	M8x1	127	DKF4025-4
DKF4030-3	40	30	40	6.35	34.9	3	36.8	77.1	508	70	70	20	100	14	85	9	2	37.5	75	M8x1	117	DKF4030-3

DKF型高速精密滚珠丝杠副

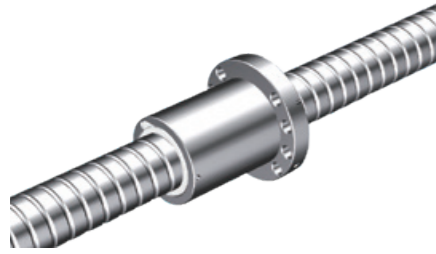

注:

- 1) K_c 是在预紧力 F_p 为 $0.1C_a$, 轴向载荷 F 为 $0.3C_a$ 时的理论计算值;
- 2) 当轴向载荷 F 不等于 $0.3C_a$ 时,

$$K'_c = K_c \left(\frac{F}{0.3C_a} \right)^{\frac{1}{3}}$$

式中

K_c 是表中的刚度值;

- 3) 该类型的滚珠丝杠副适用于高速应用场合;
- 4) 正常工作环境温度范围 $\pm 80^\circ\text{C}$;
- 5) 有特殊要求应在订货时提出。

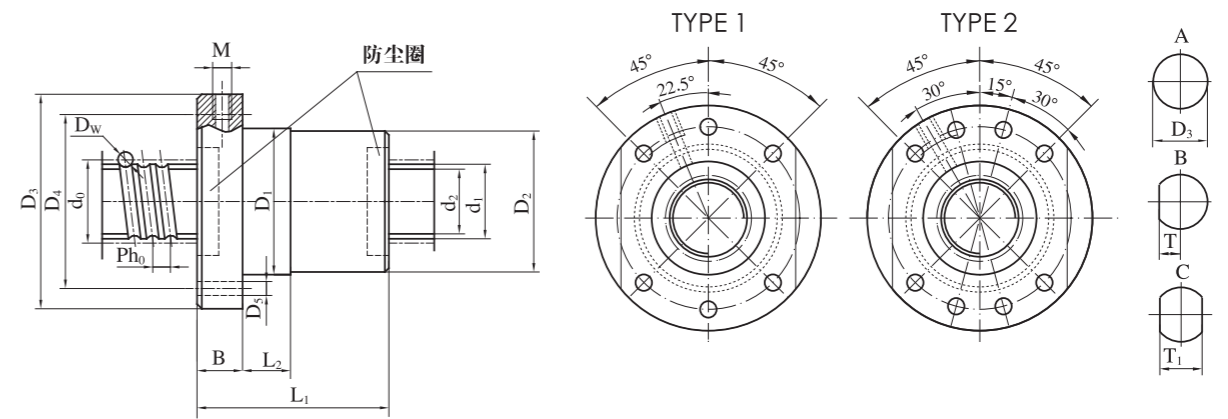

规格代号	公称直径 d_0	公称导程 P_{n0}	丝杠外径 d_1	钢球直径 D_w	丝杠底径 d_2	循环圈数 n	基本额定负荷		刚度 K_c N/ μm	螺母安装连接尺寸							规格代号					
							动载荷 C_a kN	静载荷 C_{0a} kN		D_1 (g6)	D_2 ($^{0.01}_{-0.3}$)	L_2	D_3	B	D_4	D_5		TYPE	T	T_1	M	L_1
DKF5010-4	50	10	50	6.35	44.9	4	53.4	129.9	763	82	82	20	118	16	100	11	2	46	92	M8x1	70	DKF5010-4
DKF5010-5	50	10	50	6.35	44.9	5	65.4	164.5	957	82	82	20	118	16	100	11		46	92	M8x1	80	DKF5010-5
DKF5012-4	50	12	50	6.35	44.9	4	53.3	129.8	775	82	82	20	118	16	100	11		46	92	M8x1	79	DKF5012-4
DKF5012-5	50	12	50	6.35	44.9	5	65.4	164.4	972	82	82	20	118	16	100	11		46	92	M8x1	91	DKF5012-5
DKF5016-4	50	16	50	6.35	44.9	4	53.2	129.5	789	82	82	20	118	16	100	11		46	92	M8x1	91	DKF5016-4
DKF5016-5	50	16	50	6.35	44.9	5	65.2	164.0	990	82	82	20	118	16	100	11		46	92	M8x1	107	DKF5016-5
DKF5020-4	50	20	50	6.35	44.9	4	53.0	129.1	796	82	82	20	118	16	100	11		46	92	M8x1	105	DKF5020-4
DKF5020-5	50	20	50	6.35	44.9	5	65.0	163.6	998	82	82	20	118	16	100	11		46	92	M8x1	125	DKF5020-5
DKF5025-4	50	25	50	6.35	44.9	4	52.7	128.6	798	82	82	20	118	16	100	11		46	92	M8x1	129	DKF5025-4
DKF5030-4	50	30	50	6.35	44.9	4	52.3	127.9	795	82	82	20	118	16	100	11		46	92	M8x1	145	DKF5030-4
DKF5040-3	50	40	50	6.35	44.9	3	40.4	96.2	601	82	82	20	118	16	100	11	46	92	M8x1	145	DKF5040-3	
DKF6310-5	63	10	61	6.35	56.4	5	72.2	205.9	1111	95	95	20	135	22	115	13.5	50	100	M8x1	91	DKF6310-5	
DKF6312-5	63	12	61	6.35	56.4	5	72.1	205.8	1133	95	95	20	135	22	115	13.5	50	100	M8x1	99	DKF6312-5	
DKF6312-5	63	12	61	7.938	55.3	5	98.1	256.9	1169	98	98	20	138	25	118	13.5	51.5	103	M8x1	105	DKF6312-5	
DKF6316-5	63	16	61	6.35	56.4	5	71.9	205.5	1162	95	95	30	135	22	115	13.5	50	100	M8x1	119	DKF6316-5	
DKF6316-5	63	16	61	10	53.9	5	133.7	321.8	1246	107	107	30	147	28	127	13.5	56	112	M8x1	134	DKF6316-5	
DKF6320-5	63	20	61	6.35	56.4	5	71.8	205.1	1177	95	95	40	135	22	115	13.5	50	100	M8x1	138	DKF6320-5	
DKF6320-5	63	20	61	10	53.9	5	133.4	321.2	1262	107	107	40	147	28	127	13.5	56	112	M8x1	153	DKF6320-5	
DKF6325-4	63	25	61	6.35	56.4	4	58.3	161.5	947	95	95	40	135	22	115	13.5	50	100	M8x1	138	DKF6325-4	
DKF6325-4	63	25	61	10	53.9	4	108.5	252.9	1014	107	107	40	147	28	127	13.5	56	112	M8x1	153	DKF6325-4	
DKF6330-4	63	30	61	6.35	56.4	4	58.1	160.9	949	95	95	40	135	22	115	13.5	50	100	M8x1	158	DKF6330-4	
DKF6330-4	63	30	61	10	53.9	4	108.0	252.0	1017	107	107	40	147	28	127	13.5	56	112	M8x1	172	DKF6330-4	
DKF6340-4	63	40	61	6.35	56.4	4	57.4	159.4	943	95	95	40	135	22	115	13.5	50	100	M8x1	198	DKF6340-4	
DKF6340-4	63	40	61	10	53.9	4	106.8	249.8	1010	107	107	40	147	28	127	13.5	56	112	M8x1	210	DKF6340-4	
DKF8020-5	80	20	80	9.525	72.5	5	143.4	406.0	1510	125	125	25	170	25	150	13.5	67.5	135	M8x1	140	DKF8020-5	

DKFZD型高速精密滚珠丝杠副



注:

- 1) K_c 是在预紧力 F_p 为 $0.1C_a$, 轴向载荷 F 为 $0.3C_a$ 时的理论计算值;
- 2) 当轴向载荷 F 不等于 $0.3C_a$ 时,

$$K'_c = K_c \left(\frac{F}{0.3C_a} \right)^{\frac{1}{3}}$$

式中

K_c 是表中的刚度值;

- 3) 该类型的滚珠丝杠副适用于高速应用场合;
- 4) 正常工作环境温度范围 $\pm 80^\circ\text{C}$;
- 5) 有特殊要求应在订货时提出。

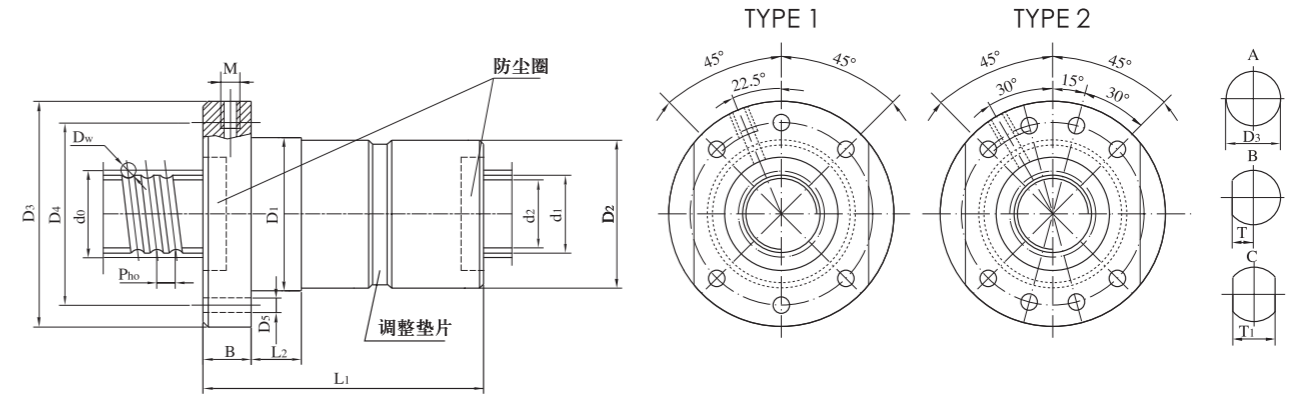

规格代号	公称直径 d_0	公称导程 P_{no}	丝杠外径 d_1	钢球直径 D_w	丝杠底径 d_2	循环圈数 n	基本额定负荷		刚度 K_c N/ μm	螺母安装连接尺寸							规格代号					
							动载荷 C_a kN	静载荷 C_{oa} kN		D_1 (g6)	D_2 ($^{+0.1}_{-0.3}$)	L_2	D_3	B	D_4	D_5		TYPE	T	T_1	M	L_1
DKFZD2510-3	25	10	25	3.969	21.7	3	15.7	29.3	522	45	45	20	65	11	54	6.6	1	25.5	51	M6	104	DKFZD2510-3
DKFZD2510-4	25	10	25	3.969	21.7	4	20.5	39.9	702	45	45	20	65	11	54	6.6	1	25.5	51	M6	124	DKFZD2510-4
DKFZD3206-4	32	6	32	3.969	28.7	4	23.4	52.8	859	53	53	20	87	12	72	9	1	31	62	M6	96	DKFZD3206-4
DKFZD3206-5	32	6	32	3.969	28.7	5	28.7	66.9	1077	53	53	20	87	12	72	9	1	31	62	M6	108	DKFZD3206-5
DKFZD3210-4	32	10	32	3.969	28.7	4	23.3	52.7	871	53	53	20	87	12	72	9	1	31	62	M6	130	DKFZD3210-4
DKFZD3210-5	32	10	32	3.969	28.7	5	28.6	66.7	1091	53	53	20	87	12	72	9	1	31	62	M6	150	DKFZD3210-5
DKFZD3210-4	32	10	32	6.35	26.9	4	42.7	80.7	903	62	62	20	92	14	77	9	1	37	74	M6	139	DKFZD3210-4
DKFZD3210-5	32	10	32	6.35	26.9	5	52.3	102.3	1132	62	62	20	92	14	77	9	1	37	74	M6	159	DKFZD3210-5
DKFZD3212-4	32	12	32	3.969	28.7	4	23.3	52.6	871	53	53	20	87	12	72	9	1	31	62	M6	140	DKFZD3212-4
DKFZD3212-5	32	12	32	3.969	28.7	5	28.5	66.6	1092	53	53	20	87	12	72	9	1	31	62	M6	164	DKFZD3212-5
DKFZD3212-4	32	12	32	6.35	26.9	4	42.6	80.6	904	62	62	20	92	14	77	9	1	37	74	M6	155	DKFZD3212-4
DKFZD3212-5	32	12	32	6.35	26.9	5	52.2	102.1	1132	62	62	20	92	14	77	9	1	37	74	M6	179	DKFZD3212-5
DKFZD3216-4	32	16	32	6.35	26.9	4	42.3	80.2	899	62	62	20	92	14	77	9	1	37	74	M6	189	DKFZD3216-4
DKFZD4010-4	40	10	40	6.35	34.9	4	48.0	102.6	1084	70	70	20	100	14	85	9	2	37.5	75	M8x1	149	DKFZD4010-4
DKFZD4010-5	40	10	40	6.35	34.9	5	58.9	130.0	1358	70	70	20	100	14	85	9	2	37.5	75	M8x1	169	DKFZD4010-5
DKFZD4012-4	40	12	40	6.35	34.9	4	47.9	102.5	1087	70	70	20	100	14	85	9	2	37.5	75	M8x1	157	DKFZD4012-4
DKFZD4012-5	40	12	40	6.35	34.9	5	58.8	129.8	1363	70	70	20	100	14	85	9	2	37.5	75	M8x1	181	DKFZD4012-5
DKFZD4015-5	40	15	40	6.35	34.9	5	58.6	129.5	1364	70	70	20	100	14	85	9	2	37.5	75	M8x1	204	DKFZD4015-5
DKFZD4016-4	40	16	40	6.35	34.9	4	47.7	102.1	1088	70	70	20	100	14	85	9	2	37.5	75	M8x1	187	DKFZD4016-4
DKFZD4016-5	40	16	40	6.35	34.9	5	58.5	129.4	1363	70	70	20	100	14	85	9	2	37.5	75	M8x1	219	DKFZD4016-5
DKFZD4020-4	40	20	40	6.35	34.9	4	47.5	101.7	1083	70	70	20	100	14	85	9	2	37.5	75	M8x1	225	DKFZD4020-4
DKFZD4020-5	40	20	40	6.35	34.9	5	58.2	128.8	1357	70	70	20	100	14	85	9	2	37.5	75	M8x1	265	DKFZD4020-5
DKFZD4025-4	40	25	40	6.35	34.9	4	47.1	101.0	1073	70	70	20	100	14	85	9	2	37.5	75	M8x1	259	DKFZD4025-4
DKFZD4030-3	40	30	40	6.35	34.9	3	36.8	77.1	821	70	70	20	100	14	85	9	2	37.5	75	M8x1	239	DKFZD4030-3

DKFZD型高速精密滚珠丝杠副



注:

- 1) K_c 是在预紧力 F_p 为 $0.1C_a$, 轴向载荷 F 为 $0.3C_a$ 时的理论计算值;
- 2) 当轴向载荷 F 不等于 $0.3C_a$ 时,

$$K'_c = K_c \left(\frac{F}{0.3C_a} \right)^{\frac{1}{3}}$$

式中

K_c 是表中的刚度值;

- 3) 该类型的滚珠丝杠副适用于高速应用场合;
- 4) 正常工作环境温度范围 $\pm 80^\circ\text{C}$;
- 5) 有特殊要求应在订货时提出。

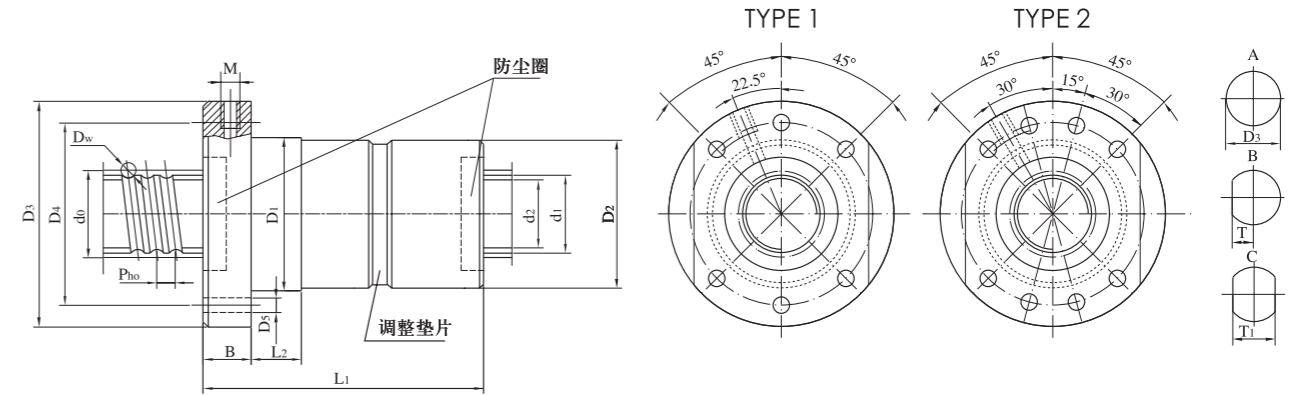

规格代号	公称直径 d_0	公称导程 P_{ho}	丝杠外径 d_1	钢球直径 D_w	丝杠底径 d_2	循环圈数 n	基本额定负荷		刚度 K_c N/ μm	螺母安装连接尺寸							规格代号					
							动载荷 C_a kN	静载荷 C_{0a} kN		D_1 (g6)	D_2 ($^{0.1}_{-0.3}$)	L_2	D_3	B	D_4	D_5		TYPE	T	T_1	M	L_1
DKFZD5010-4	50	10	50	6.35	44.9	4	53.4	129.9	1293	82	82	20	118	16	100	11	2	46	92	M8×1	145	DKFZD5010-4
DKFZD5010-5	50	10	50	6.35	44.9	5	65.4	164.5	1620	82	82	20	118	16	100	11	2	46	92	M8×1	165	DKFZD5010-5
DKFZD5012-4	50	12	50	6.35	44.9	4	53.3	129.8	1300	82	82	20	118	16	100	11	2	46	92	M8×1	163	DKFZD5012-4
DKFZD5012-5	50	12	50	6.35	44.9	5	65.4	164.4	1629	82	82	20	118	16	100	11	2	46	92	M8×1	187	DKFZD5012-5
DKFZD5016-4	50	16	50	6.35	44.9	4	53.2	129.5	1307	82	82	20	118	16	100	11	2	46	92	M8×1	187	DKFZD5016-4
DKFZD5016-5	50	16	50	6.35	44.9	5	65.2	164.0	1637	82	82	20	118	16	100	11	2	46	92	M8×1	219	DKFZD5016-5
DKFZD5020-4	50	20	50	6.35	44.9	4	53.0	129.1	1307	82	82	20	118	16	100	11	2	46	92	M8×1	215	DKFZD5020-4
DKFZD5020-5	50	20	50	6.35	44.9	5	65.0	163.6	1637	82	82	20	118	16	100	11	2	46	92	M8×1	255	DKFZD5020-5
DKFZD5025-4	50	25	50	6.35	44.9	4	52.7	128.6	1301	82	82	20	118	16	100	11	2	46	92	M8×1	263	DKFZD5025-4
DKFZD5030-4	50	30	50	6.35	44.9	4	52.3	127.9	1291	82	82	20	118	16	100	11	2	46	92	M8×1	295	DKFZD5030-4
DKFZD5040-3	50	40	50	6.35	44.9	3	40.4	96.2	971	82	82	30	118	16	100	11	2	46	92	M8×1	295	DKFZD5040-3
DKFZD6310-5	63	10	61	6.35	56.4	5	72.2	205.9	1911	95	95	20	135	22	115	13.5	2	50	100	M8×1	168	DKFZD6310-5
DKFZD6312-5	63	12	61	6.35	56.4	5	72.1	205.8	1926	95	95	20	135	22	115	13.5	2	50	100	M8×1	180	DKFZD6312-5
DKFZD6312-5	63	12	61	7.938	55.3	5	98.1	256.9	1990	98	98	20	138	25	118	13.5	2	51.5	103	M8×1	198	DKFZD6312-5
DKFZD6316-5	63	16	61	6.35	56.4	5	71.9	205.5	1943	95	95	30	135	22	115	13.5	2	50	100	M8×1	227	DKFZD6316-5
DKFZD6316-5	63	16	61	10	53.9	5	133.7	321.8	2079	107	107	30	147	28	127	13.5	2	56	112	M8×1	242	DKFZD6316-5
DKFZD6320-5	63	20	61	6.35	56.4	5	71.8	205.1	1950	95	95	40	135	22	115	13.5	2	50	100	M8×1	263	DKFZD6320-5
DKFZD6320-5	63	20	61	10	53.9	5	133.4	321.2	2085	107	107	40	147	28	127	13.5	2	56	112	M8×1	288	DKFZD6320-5
DKFZD6325-4	63	25	61	6.35	56.4	4	58.3	161.5	1556	95	95	40	135	22	115	13.5	2	50	100	M8×1	257	DKFZD6325-4
DKFZD6325-4	63	25	61	10	53.9	4	108.5	252.9	1664	107	107	40	147	28	127	13.5	2	56	112	M8×1	283.5	DKFZD6325-4
DKFZD6330-4	63	30	61	6.35	56.4	4	58.1	160.9	1550	95	95	40	135	22	115	13.5	2	50	100	M8×1	301	DKFZD6330-4
DKFZD6330-4	63	30	61	10	53.9	4	108.0	252.0	1658	107	107	40	147	28	127	13.5	2	56	112	M8×1	331	DKFZD6330-4
DKFZD6340-3	63	40	61	6.35	56.4	3	44.0	116.9	1138	95	95	40	135	22	115	13.5	2	50	100	M8×1	309	DKFZD6340-3
DKFZD6340-3	63	40	61	10	53.9	3	81.8	183.2	1217	107	107	40	147	28	127	13.5	2	56	112	M8×1	320	DKFZD6340-3
DKFZD8020-5	80	20	80	9.525	72.5	5	143.4	406.0	2533	125	125	25	170	25	150	13.5	2	67.5	135	M8×1	290	DKFZD8020-5

DKF 紧凑型高速精密滚珠丝杠副

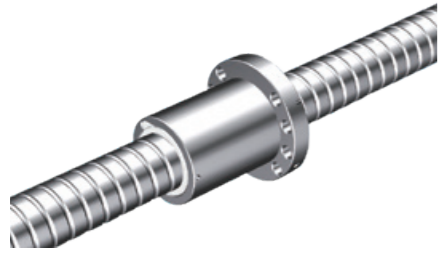

注:

- 1) K_c 是在预紧力 F_p 为 $0.1C_a$, 轴向载荷 F 为 $0.3C_a$ 时的理论计算值;
- 2) 当轴向载荷 F 不等于 $0.3C_a$ 时,

$$K'_c = K_c \left(\frac{F}{0.3C_a} \right)^{\frac{1}{3}}$$

式中

- K_c 是表中的刚度值;
- 3) 该类型的滚珠丝杠副适用于高速应用场合;
 - 4) 正常工作环境温度范围 $\pm 80^\circ\text{C}$;
 - 5) 有特殊要求应在订货时提出。

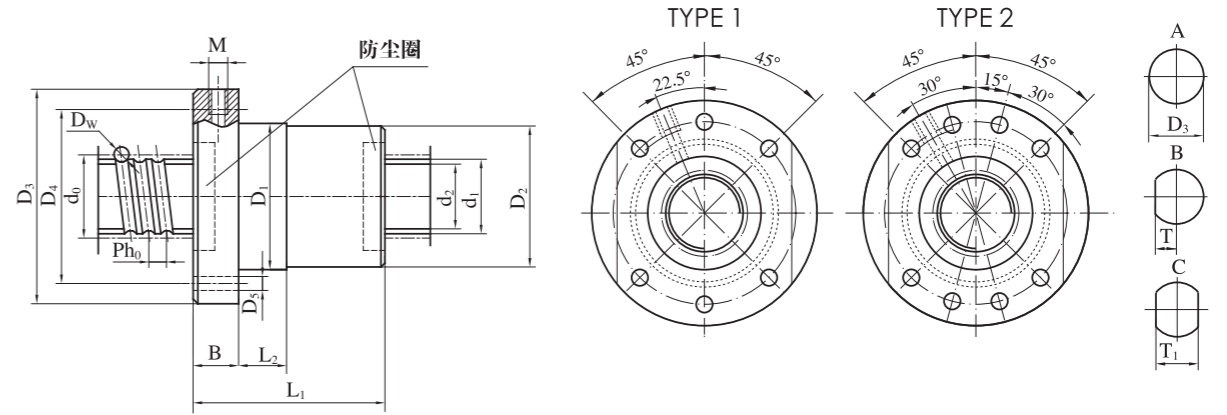

规格代号	公称直径 d_0	公称导程 P_{h0}	丝杠外径 d_1	丝杠底径 d_2	钢球直径 D_w	循环圈数 n	基本额定负荷		刚度 K_c N/ μm	螺母安装连接尺寸											规格代号		
							动载荷 C_a kN	静载荷 C_{0a} kN		$D_1(g6)$	$D_2(\frac{h6}{g5})$	L_2	D_3	B	D_4	D_5	TYPE	T	T_1	M		L_1	
DKF2510-4-J	25	10	25	21.1	4.763	4	26.2	48.3	441	45	45	10	65	15	54	6.6	1	25.5	51	M6	63	DKF2510-4-J	
DKF2520-2-J	25	20	25	22.3	3.175	2	7.9	15.3	204	40	40	15	62	12	51	6.6		24	48	M6	59	DKF2520-2-J	
DKF3210-4-J	32	10	32	26.9	6.35	4	42.7	80.7	547	57	57	15	87	16	72	9		34.5	69	M8X1	66	DKF3210-4-J	
DKF3210-5-J	32	10	32	26.9	6.35	5	52.3	102.3	686	57	57	15	87	16	72	9		34.5	69	M8X1	76	DKF3210-5-J	
DKF3212-4-J	32	12	32	26.9	6.35	4	42.6	80.6	551	57	57	15	87	16	72	9		34.5	69	M8X1	75	DKF3212-4-J	
DKF3212-5-J	32	12	32	26.9	6.35	5	52.2	102.1	690	57	57	15	87	16	72	9		34.5	69	M8X1	87	DKF3212-5-J	
DKF3216-4-J	32	16	32	26.9	6.35	4	42.3	80.2	553	57	57	15	87	16	72	9		34.5	69	M8X1	90	DKF3216-4-J	
DKF4010-4-J	40	10	40	34.9	6.35	4	48.0	102.6	648	65	65	20	95	18	80	9		2	36	72	M8X1	68	DKF4010-4-J
DKF4010-5-J	40	10	40	34.9	6.35	5	58.9	130.0	813	65	65	20	95	18	80	9			36	72	M8X1	78	DKF4010-5-J
DKF4012-4-J	40	12	40	34.9	6.35	4	47.9	102.5	656	65	65	20	95	18	80	9			36	72	M8X1	76	DKF4012-4-J
DKF4012-5-J	40	12	40	34.9	6.35	5	58.8	129.8	822	65	65	20	95	18	80	9	36		72	M8X1	88	DKF4012-5-J	
DKF4016-4-J	40	16	40	34.9	6.35	4	47.7	102.1	663	65	65	20	95	18	80	9	36		72	M8X1	92	DKF4016-4-J	
DKF4016-5-J	40	16	40	34.9	6.35	5	58.5	129.4	831	65	65	20	95	18	80	9	36		72	M8X1	108	DKF4016-5-J	
DKF5010-4-J	50	10	50	44.9	6.35	4	53.4	129.9	763	75	75	20	118	18	100	11	46		92	M8X1	68	DKF5010-4-J	
DKF5010-5-J	50	10	50	44.9	6.35	5	65.4	164.5	957	75	75	20	118	18	100	11	46		92	M8X1	78	DKF5010-5-J	
DKF5012-4-J	50	12	50	44.9	6.35	4	53.3	129.8	775	75	75	20	118	18	100	11	46		92	M8X1	75	DKF5012-4-J	
DKF5012-5-J	50	12	50	44.9	6.35	5	65.4	164.4	972	75	75	20	118	18	100	11	46		92	M8X1	87	DKF5012-5-J	
DKF5016-4-J	50	16	50	44.9	6.35	4	53.2	129.5	789	75	75	20	118	18	100	11	46	92	M8X1	93	DKF5016-4-J		
DKF5016-5-J	50	16	50	44.9	6.35	5	65.2	164.0	990	75	75	20	118	18	100	11	46	92	M8X1	109	DKF5016-5-J		

DKFZD紧凑型高速精密滚珠丝杠副



注:

- 1) K_c 是在预紧力 F_p 为 $0.1C_a$, 轴向载荷 F 为 $0.3C_a$ 时的理论计算值;
- 2) 当轴向载荷 F 不等于 $0.3C_a$ 时,

$$K'_c = K_c \left(\frac{F}{0.3C_a} \right)^{\frac{1}{3}}$$

式中

K_c 是表中的刚度值;

- 3) 该类型的滚珠丝杠副适用于高速应用场合;
- 4) 正常工作环境温度范围 $\pm 80^\circ\text{C}$;
- 5) 有特殊要求应在订货时提出。

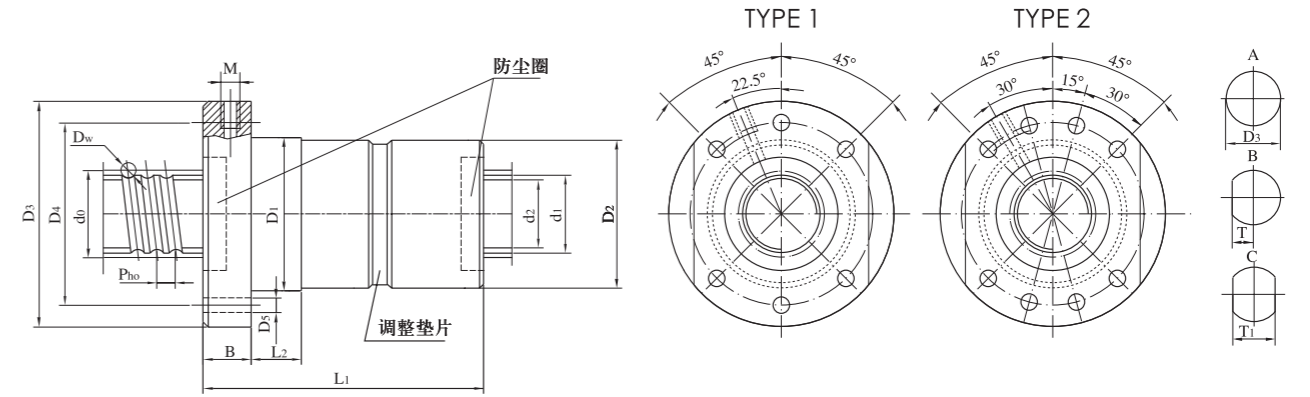

规格代号	公称直径 d_0	公称导程 P_{ho}	丝杠外径 d_1	丝杠底径 d_2	钢球直径 D_w	循环圈数 n	基本额定负荷		刚度 K_c N/ μm	螺母安装连接尺寸											规格代号	
							动载荷 C_a kN	静载荷 C_{oa} kN		D_1 (g6)	D_2 ($^{-0.1}_{+0.3}$)	L_2	D_3	B	D_4	D_5	TYPE	T	T_1	M		L_1
DKFZD2510-4-J	25	10	25	21.1	4.763	4	26.2	48.3	441	45	45	10	65	15	54	6.6	1	25.5	51	M6	63	DKFZD2510-4-J
DKFZD2520-2-J	35	20	25	22.3	3.175	2	7.9	15.3	204	40	40	15	62	12	51	6.6		24	48	M6	59	DKFZD2520-2-J
DKFZD3210-4-J	32	10	32	26.9	6.35	4	42.7	80.7	903	57	57	15	87	16	72	9	1	34.5	69	M8X1	129	DKFZD3210-4-J
DKFZD3210-5-J	32	10	32	26.9	6.35	5	52.3	102.3	1132	57	57	15	87	16	72	9		34.5	69	M8X1	149	DKFZD3210-5-J
DKFZD3212-4-J	32	12	32	26.9	6.35	4	42.6	80.6	904	57	57	15	87	16	72	9	1	34.5	69	M8X1	147	DKFZD3212-4-J
DKFZD3212-5-J	32	12	32	26.9	6.35	5	52.2	102.1	1132	57	57	15	87	16	72	9		34.5	69	M8X1	171	DKFZD3212-5-J
DKFZD3216-4-J	32	16	32	26.9	6.35	4	42.3	80.2	899	57	57	15	87	16	72	9	1	34.5	69	M8X1	182	DKFZD3216-4-J
DKFZD4010-4-J	40	10	40	34.9	6.35	4	48.0	102.6	1084	65	65	20	95	18	80	9		2	36	72	M8X1	135
DKFZD4010-5-J	40	10	40	34.9	6.35	5	58.9	130.0	1358	65	65	20	95	18	80	9	36		72	M8X1	155	DKFZD4010-5-J
DKFZD4012-4-J	40	12	40	34.9	6.35	4	47.9	102.5	1087	65	65	20	95	18	80	9	2	36	72	M8X1	148	DKFZD4012-4-J
DKFZD4012-5-J	40	12	40	34.9	6.35	5	58.8	129.8	1363	65	65	20	95	18	80	9		36	72	M8X1	172	DKFZD4012-5-J
DKFZD4016-4-J	40	16	40	34.9	6.35	4	47.7	102.1	1088	65	65	20	95	18	80	9	2	36	72	M8X1	181	DKFZD4016-4-J
DKFZD4016-5-J	40	16	40	34.9	6.35	5	58.5	129.4	1363	65	65	20	95	18	80	9		36	72	M8X1	213	DKFZD4016-5-J
DKFZD5010-4-J	50	10	50	44.9	6.35	4	53.4	129.9	1293	75	75	20	118	18	100	11	2	46	92	M8X1	136	DKFZD5010-4-J
DKFZD5010-5-J	50	10	50	44.9	6.35	5	65.4	164.5	1620	75	75	20	118	18	100	11		46	92	M8X1	156	DKFZD5010-5-J
DKFZD5012-4-J	50	12	50	44.9	6.35	4	53.3	129.8	1300	75	75	20	118	18	100	11	2	46	92	M8X1	151	DKFZD5012-4-J
DKFZD5012-5-J	50	12	50	44.9	6.35	5	65.4	164.4	1629	75	75	20	118	18	100	11		46	92	M8X1	175	DKFZD5012-5-J
DKFZD5016-4-J	50	16	50	44.9	6.35	4	53.2	129.5	1307	75	75	20	118	18	100	11	2	46	92	M8X1	181	DKFZD5016-4-J
DKFZD5016-5-J	50	16	50	44.9	6.35	5	65.2	164.0	1637	75	75	20	118	18	100	11		46	92	M8X1	213	DKFZD5016-5-J

DKF大导程高速滚珠丝杠副



注:

- 1) K_c 是在预紧力 F_p 为 $0.1C_a$, 轴向载荷 F 为 $0.3C_a$ 时的理论计算值;
- 2) 当轴向载荷 F 不等于 $0.3C_a$ 时,

$$K'_c = K_c \left(\frac{F}{0.3C_a} \right)^{\frac{1}{3}}$$

式中

K_c 是表中的刚度值;

- 3) 该类型的滚珠丝杠副适用于高速应用场合;
- 4) 正常工作环境温度范围 $\pm 80^\circ\text{C}$;
- 5) 有特殊要求应在订货时提出。

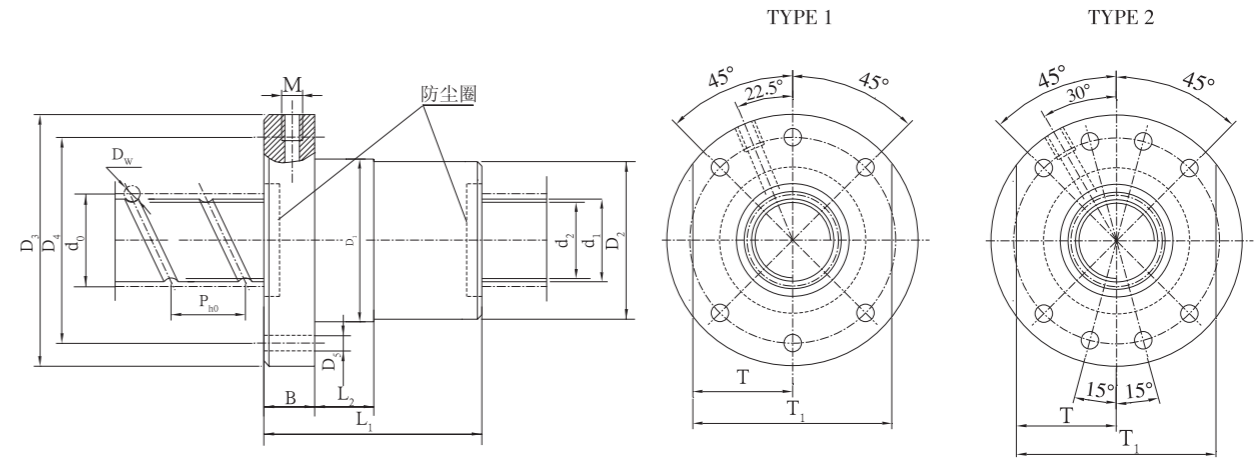

规格代号	公称直径 d_0	公称导程 P_{ho}	丝杠外径 d_1	丝杠底径 d_2	钢球直径 D_w	循环圈数 n	基本额定负荷		刚度 K_c N/ μm	螺母安装连接尺寸										规格代号		
							动载荷 C_a kN	静载荷 C_{oa} kN		D_1 (g6)	D_2 ($\frac{0.1}{0.3}$)	L_2	D_3	B	D_4	D_5	TYPE	T	T_1		M	L_1
DKF1616-2	16	16	16	13.7	2.778	2	5.2	8.3	358	32	32	10	53	12	42	4.5	1	17	34	M6	45	DKF1616-2
DKF2020-2	20	20	20	17.4	3.175	2	7.0	12.0	441	39	39	10	62	12	50	6.6	1	24	48	M6	60	DKF2020-2
DKF2525-2	25	25	25	22	3.969	2	10.4	18.8	544	47	47	10	68	12	57	6.6	1	27	54	M6	72	DKF2525-2
DKF3232-2	32	32	32	28.1	4.763	2	13.4	23.8	573	54	54	10	86	14	71	9	1	33	66	M6	88	DKF3232-2
DKF3240-2	32	40	32	28.2	5	2	15.7	30.2	665	58	58	10	88	14	73	9	1	33	66	M6	112	DKF3240-2
DKF4040-2	40	40	40	34.9	6.35	2	24.3	47.9	840	70	70	20	100	14	85	9	2	37.5	75	M8X1	101	DKF4040-2
DKF5050-2	50	50	50	44.9	6.35	2	26.8	60.1	1000	82	82	30	118	16	100	11	2	46	92	M8X1	134	DKF5050-2
DKF6363-2	63	63	61	56.4	6.35	2	29.2	74.4	1179	95	95	30	135	22	115	13.5	2	50	100	M8X1	160	DKF6363-2
DKF8040-4	80	40	78	68.9	12.7	4	216.7	563.8	4273	140	140	30	190	32	165	13.5	2	80	160	M8X1	231	DKF8040-4
DKF10040-4	100	40	97	87.9	12.7	4	242.5	715.9	5127	160	160	30	220	36	190	17.5	2	90	180	M8X1	230	DKF10040-4
DKF10050-4	100	50	97	87.9	12.7	4	241.1	712.7	5127	160	160	30	220	36	190	17.5	2	90	180	M8X1	270	DKF10050-4
DKF10050-4	100	50	97	85.6	15.875	4	324.1	880.6	5259	170	170	30	244	36	210	22	2	95	190	M8X1	270	DKF10050-4
DKF12560-3	125	60	124	114.4	12.7	3	202.1	655.4	4531	190	190	30	264	36	220	22	2	110	220	M8X1	250	DKF12560-3